

Medical/Professional Office For Lease

OFFICE



FEATURES

- **4,570 SF Total Available**
- Medical/Professional Office Park
- Near St. Luke Hospital
- Single story
- Parking at your door
- Close to shopping, restaurants, amenities
- Minutes to I-71/75 and Florence Mall
- Join tenants: Primary Pediatrics and Moore Dental Services
- Lease: \$14.00/SF NNN

LOCATION

**59 Cavalier Blvd.
Florence, KY 41042**

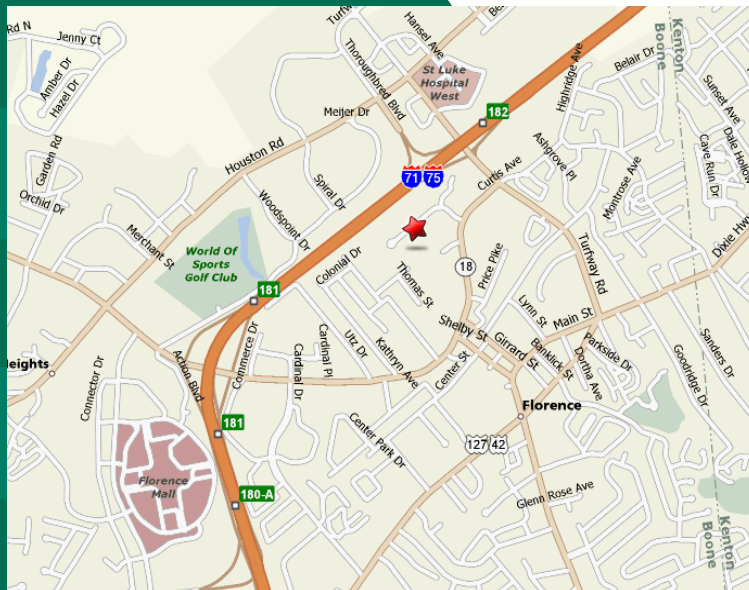

CONTACT

Chris Vitori

chris.vitori@everestrealstate.com

513/769-2510

The information submitted is not guaranteed. Although obtained from reliable sources, it is subject to errors, omissions, prior sale and withdrawal from the market without notice.



COMMERCIAL REAL ESTATE SERVICES

WEB www.everestrealstate.com TEL 513-769-2500 FAX 513-769-2512

9912 Carver Road, Sycamore Office Park, Suite 100, Cincinnati, Ohio 45242

Everest is the Greater Cincinnati/
Northern Kentucky affiliate for:



A world of real estate expertise
with over 200 offices
in Canada, U.S., Europe,
Asia, South America,
and Australia.

59 CAVALIER

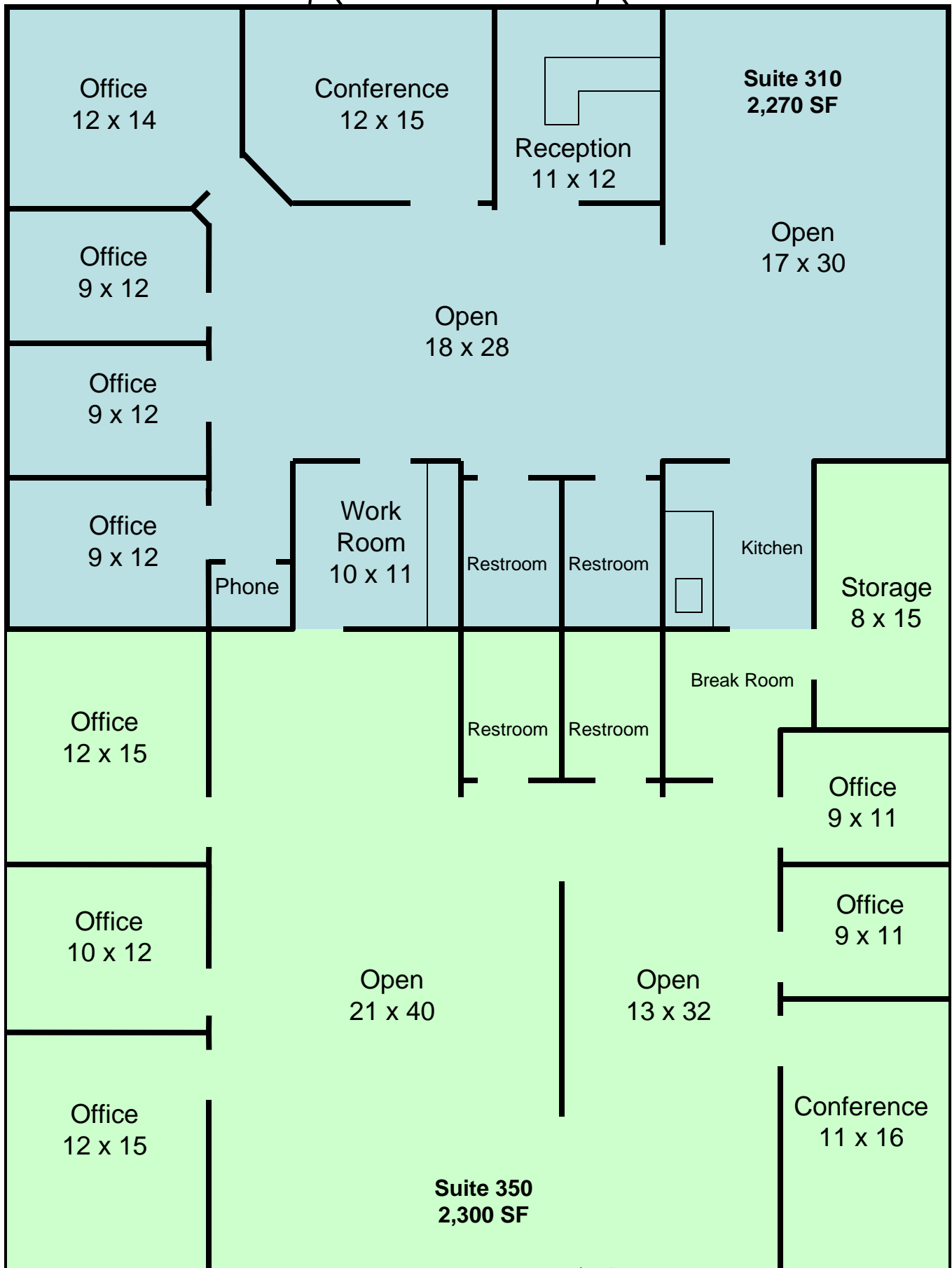

All Dimensions Approximate
Not to Scale

4,570 SF Total